



Copyright © 2011 Boart Longyear. All rights reserved.

STOPEMATE™ ROCK DRILL

Rock Drill and Blast Rig Technical Overview

STOPEMATE™

The StopeMate™ Production Drill is unique by design and created specifically to satisfy the demands of the market for a simple and robust drilling platform that can handle most drilling requirements, especially in tight situations.

Sized to fit:

- Able to tram through a 1.27 x 1.9 m (4.17 x 6.25 ft) opening with pivoting traverse feature
- Back height drilling can be as low as 2.44 m (8 ft) — based on a 1 m (3 ft) rod change
- Can fit into most cages with no disassembly



For more information on the StopeMate™ Production Drill scan with a QR code reader on your smart phone.

PRODUCTIVITY THROUGH SAFE, RELIABLE AND TRUSTED DESIGN

POSITIONING SYSTEM

A key feature of the StopeMate is the ability to drill a complete drop raise pattern from a single position, ensuring parallel holes which is a critical consideration in longhole drilling, where straight holes mean less dilution and more productivity.

Boart Longyear is the first company to incorporate the optional Helac Positioning System into our longhole production drills. The design of this positioning system gives you both the flexibility and smooth operation to drill along a 360° radius with extreme accuracy. The traverse can also easily pivot more than 180° in a very tight space – without ever moving the carrier.

S36 IR ROCK DRILL

The driving force behind the StopeMate is the S36 Independent Rotation Pneumatic Rock Drill, a powerful 114 mm (4.49 in) diameter bore drifter-type drill designed for deep hole drilling. In favourable ground conditions, the S36 IR can drill 37 m (122 ft).

With that kind of power and mobility, the StopeMate is the “go-to” rig for everything from fan drilling, pillar recovery and narrow vein parallel drilling to ring drilling, service holes, drop raises and cable bolting.



- Fully pneumatic operation - ideal for captive areas and narrow vein mining
- Modular design with efficient dismantling and reassembly - it can be transported rapidly, even into captive areas, decreasing move time and increasing productivity
- Consistent, high performance drilling regardless of varying operator skill levels or conditions decreased maintenance costs with routine maintenance being done in the stope and increased time between scheduled preventive maintenance

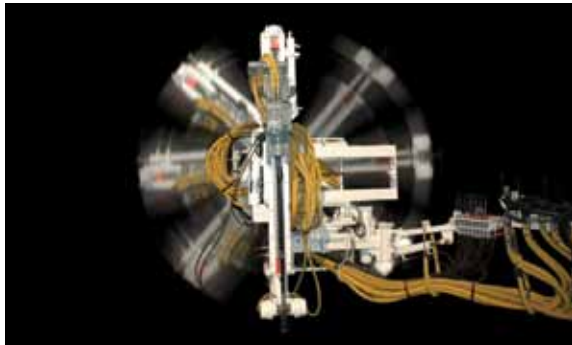

Delivering high productivity drilling and low cost in a compact package.

Compact

- Ideal for narrow vein applications

Mobile

- Easily hoisted through standard man way skip compartments

Simple

- Low maintenance cost

Versatile

- Fits more drilling patterns than any other platform on the market

TECHNICAL INFORMATION

IR Rock Drill Specification:		
	Metric	U.S.
Hydraulic Powerpack (Air Operated)		
Radial Piston Air Motor	22 kW	30 hp
Tandem gear pump	68 L/min	18 gpm
Return oil filter	10 micron	
Main reservoir	98 liters	26 gallons
Oil lubricator (rock drill) Secan F61	9 liters	2 gallon

Minimum Requirements to Drill		
	Metric	U.S.
Air flow @ 90 psi	16 m ³ /min	575 cfm
Water Flow	38 L/min	10 gpm

Note: Higher water flow is required on deeper, larger diameter downholes

Carrier
4 wheel skid steer
Gradeability - 30%
4 wheel independent drive and braking (SAHR) system
Solid rubber tires on steel rims
Motion control valving for precise control, even over rough terrain
Quick disconnect brakes for easy towing

Drill Positioner		
	Metric	U.S.
Dump - +10° to -45° movement via hydraulic cylinder c/w lock valve and mechanical expanding pivot pins		
Traverse - side to side travel	1.219 m	48 in
adjustable pads to compensate for wear		
movement via hydraulic motor driven feed screw		
heavy duty rotation slew bearing driven by hydraulic cylinder for 90° traverse rotation		
Rotation - dual hydraulic rack and pinion rotary actuator c/w manual locking system for 360° rotation		
Optional HELAC® feed positioner for increased flexibility and accuracy		

Stabilizers		
4 hydraulic cylinders	Metric	U.S.
Stroke	0.38 m	15 in
Lift	0.18 m	7 in

Rock drill Feed System	
MKV series feed assembly c/w:	Steel feed with stainless steel wear guides and rotary screw drive
	Integral cushions at end of travel
	Pneumatic opposed piston type centralizer
	Manual feed crowd

Controls
Direct acting feed positioning controls
Pivoting tramming control arm

Noise Suppression
Standard Dual exhaust, muffler and exhaust on controls rerouted

Rock Drill
S36IR - see S36IR Hydraulic Rock Drill Tech Data

Options		
Traverse travel (center line to center line)	.76 m, .91 m, 1.52 m	30 in, 36 in, 60 in
Laser hole alignment system		

DIMENSIONS AND WEIGHTS

Overall Weight: 37650 kg (8250 lb)		
	Metric	U.S.
Raise Transport - Undercarriage (largest module only)		
Length	2794 mm	110 in
Width	1220 mm	48 in
Height	813 mm	32 in
Weight	1795 kg	3950 lb
Cage Transport - Traverse Rotates 90° to reduce width for cage transport		

Minimum Parallel Hole Drilling Height			
	Metric	U.S.	"A"
Drill Steel Size	1.22 m Rod Change (Standard)	4 ft	2743 mm (108 in)
Water Flow	0.91 m Rod Change	3 ft	2438 mm (96 in)
	1.52 m Rod Change	5 ft	3048 mm (109 in)

Ring or Fan Drilling Envelope			
	Metric	U.S.	"B"
Drill Steel Size	1.22 m Rod Change (Standard)	4 ft	2463 mm (97 in)
	0.91 m Rod Change	3 ft	2247 mm (88 in)
	1.52 m Rod Change	5 ft	2769 mm (109 in)

Machine Width "C"		
	Overall	Center to Center Drill Movement
Standard Traverse	1677 mm (66 in)	1219 mm (48 in)
Optional Traverse	1219 mm (48 in)	761 mm (30 in)
"A", "B", "C" - see following page for drawings		

StopeMate™ Series Production Drill

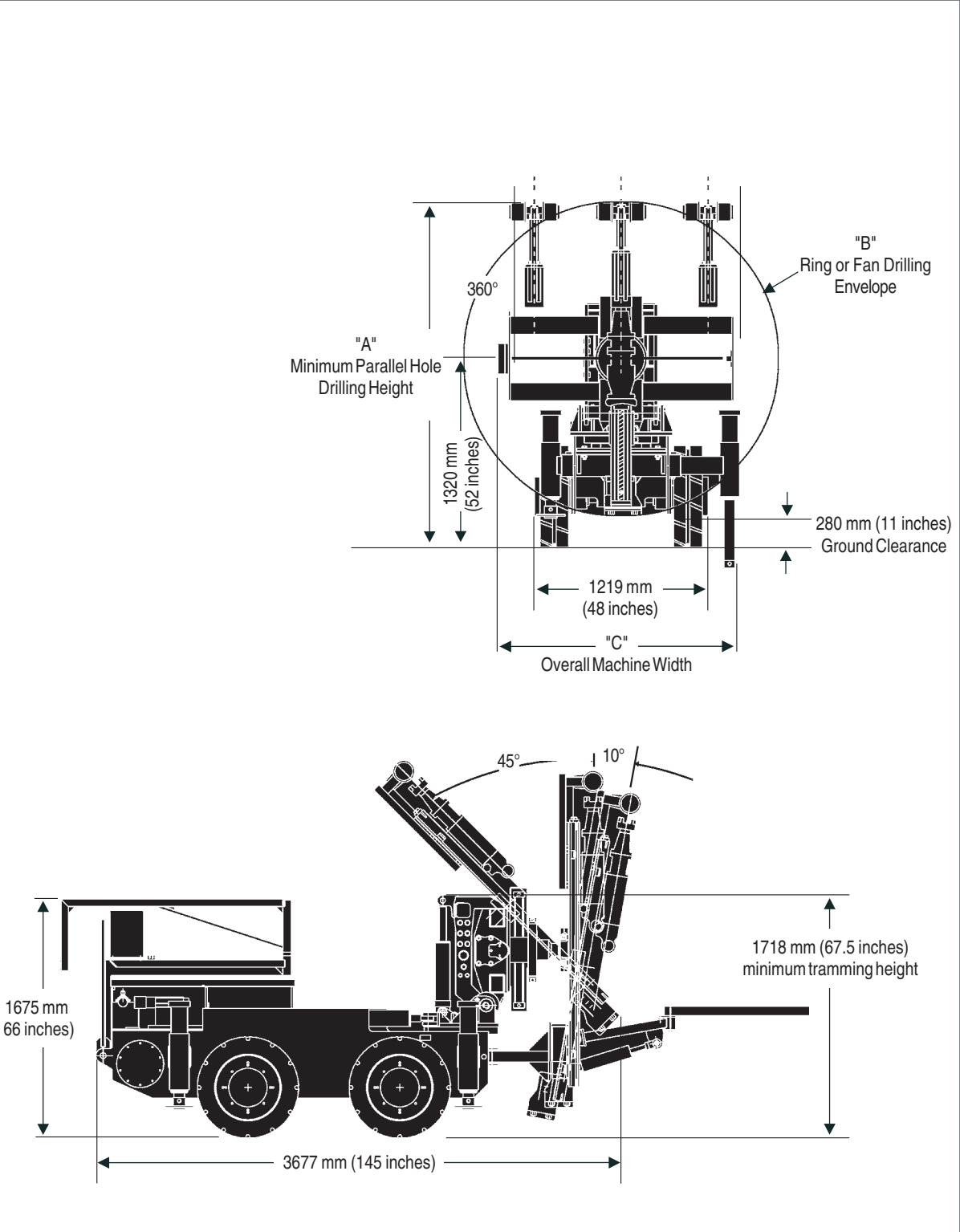

Note: Dimensions and weights may vary depending on options and should be checked before crating or lifting.



Global Headquarters

Boart Longyear
10808 South River Front Parkway
Suite 600
South Jordan, Utah 84095
United States of America
info@boartlongyear.com

Tel: +1 801 972 6430
Fax: +1 801 977 3374

Canada

Boart Longyear
2442 South Sheridan Way
Mississauga, Ontario
Canada L5J 2M7
info@boartlongyear.com

Tel: +1 905 822-7922
Fax: +1 905 822-7232

Asia Pacific

Boart Longyear
26 Butler Boulevard
Adelaide, 5950
Australia
infoAP@boartlongyear.com

Tel: +61 8 8375 8375
Fax: +61 8 8375 8497

Latin America

Boart Longyear
Portal Riesco
Av. El Salto 4001, Huechuraba
Santiago, Chile 858 0641
infochile@boartlongyear.com

Tel: +56 2 595 3300
Fax: +51 242 671

Europe

Boart Longyear
12 Avenue des Morgines
CH1213 Petit-Lancy,
Geneva, Switzerland
infoEU@boartlongyear.com

Tel: +41 22 709 0800
Fax: +41 22 709 0801

Sub-Saharan Africa

Boart Longyear
Cycad House, Constantia Office Park
Cnr 14th Avenue and Hendrik Potgieter
Weltevreden Park, 1709
Gauteng, South Africa
infosasa@boartlongyear.com

Tel: +27 11 767 9300
Fax: +27 11 767 9301

ROCK DRILL AND BLAST DRILLING PRODUCTS



Percussive Bits



Percussive Rods



StopeMaster™ Drill